



Specification Approval Sheet

产品规格确认书

Product Name 产品名称	Li-ion Polymer Battery
Model SPEC 型号规格	803565/2500mAh/3.7V
Company Name 客户名称	
Document Number 文件编号	JZB1609210835
Sample Number 样品单编号	
Document Revision 文件版本	A0

Approved By 批准	Checkup 审核	Make 制定

Customer Confirmation 客户确认	Signature 签名	Date 日期
	Company Name: 公司名称:	
	Company Stamp: 公司印章:	



AMENDMENT RECORDS

(规格变更记录)

Modification Time	Description	Issued Date	Approved By
0	New release	2016-09-22	

Content

目 录

Scope	
适用范围.....	4
Description	
说明.....	4
Specification	
产品规格.....	4
Battery Cell Performance Criteria	
电芯性能标准.....	6
Storage and others	
贮存及其它事项.....	9
Repair period	
包修期限.....	9
Assembly diagram (not to scale)	
装配示意图.....	10
Handling Precautions and Guideline	
操作指示及注意事项.....	11
Charging	
充电.....	11
Discharging Current	
放电电流.....	12
Discharging Temperature	
放电温度.....	12
Over-Discharge	
过放电.....	12
Protection Circuit Module(PCM)	
保护电路模块.....	12
Storage	
贮存.....	13
Notice	
注意事项.....	13
Other Notice	
其它注意事项.....	15
Recommended Notice	
推荐使用事项.....	16
▲Special Notice	
特别提醒.....	16

Any copies are invalid without our company's approval

本资料未经本公司批准自行影印，视为无效

Lithium Ion polymer battery

1. Scope:

适用范围:

This document is made according to customer parameter requirements, it describes the Product Specification of Chargeable Lithium Polymer Battery pack produced by Guangzhou Jiezhentech Technology Co., Ltd.

本规格书是广州捷臻科技有限公司根据客户提供参数要求双方制定的可充聚合物锂离子电池组。

2. Description

说明

2.1 Model: 803565

型号: 803565

2.2 Assembly Way

装配方式

Single cell packed with PCM, wire and PH-2P

单电芯加板加线加插头 PH-2P

3. Specification

产品规格:

3.1 The fundamental parameters of the cell

No.	Item	Spec	Note
1	Charge Voltage 充电电压	3.7V	
2	Overcharge protection voltage 过充保护电压	(4.25±0.05V)	
3	Nominal Voltage 标称电压	3.7V	The average value of voltage during the discharge period (with standard charge and discharge). When shipping, the voltage without load is between 3.6V and 3.85V. 按标准充放电后，放电过程中的电压平均值。出货时，电芯空载电压在 3.6V~3.85V 之间。
4	Nominal Capacity 额定容量	Typ:2500mAh@ 0.2C Discharge(放电) Min: 2400mAh	Nominal Capacity refer to the capacity of 0.2C discharge to 6.0V cut-off voltage, after charging with standard method. 额定容量是指用标准方法充电后，用 0.2C 电流放电至 3.0V 的容量。
5	Charge Current 充电电流	Cell surface Temperature (电芯表面温度)	Charge Current (充电电流)
		<0° C	禁止充电 Charge shall be prohibited
		0°C~10°C	0.1C Max (CV: 3.8V Max)
		10°C~15°C	0.2C Max

Lithium Ion polymer battery

		15°C~25°C	0.5C Max
		25°C~45°C	1.0C Max
6	Standard Charging method 标准充电方法	CC/CV	0.2CCC(constant current) charge to 4.2V, then CV(constant voltage 4.2V) charge till charge current decline to $\leq 0.05C$ 0.2C CC (恒流) 充电至 4.2V, 再 CV (恒压 4.2V) 充电直至充电电流 $\leq 0.05C$.
7	Cycle Life 循环寿命	≥ 300 Times	One cycle refer to one charge period and then one discharge period. Test condition: Charge: 0.2C to 17.4V Discharge: 0.2C to 12.0V The cycle life is the cycle times when the discharge capacity is about 75% of the rated capacity. 一个循环是指一次充放电周期 (25°C \pm 1°C, 充放电电流为 0.2C, 3.0V 为截止电压)。当放电容量约为额定容量的 75%时, 所完成的循环次数定义为该电芯的循环寿命。
8	Initial Impedance 初始内阻	$\leq 120m\Omega$	Internal resistance measured at AC 1KHz after 50% charge 半充状态下, 测量其 AC 1KHz 下的交流阻抗
9	Max. Charge Current 最大充电电流	0.5C	
10	Max. Discharge Current 最大放电电流	1.0C	
11	Over discharge detection Voltage 过放保护电压	(3.0 \pm 0.1V)	
12	Operating Temperature 工作温度	Discharge: -10°C ~ +60°C (放电) Charge: 0°C ~ +45°C (充电)	
13	long term storage temperature 长期储存温度	-5 °C ~ +35°C	Relative humidity 相对湿度: 45~75%RH Voltage: 3.8 \pm 0.1V (single cell) Cells must be stored at 3.6V ~ 3.85V. Over long storage periods cells should be cycled every 90 days. The method is to do a charge-discharge cycle with standard method, then charge to 3.6V ~ 3.85V.

Lithium Ion polymer battery

			电芯应在 3.6V ~ 3.85V 状态下储存。过长时间储存的电芯应每隔 90 天用标准方法适时地进行一次充放电循环。
14	Weight 重量	Approx: 38g 约: 38g	
15	PCM		
16	Assemblage Dimension 装配尺寸	Length: 65.0mm Max Width: 35.0mm Max Thickness: 8.0mm Max	Measured weight of 300gf at 25°C ± 1°C. Not including battery drawing line. 测量时测量仪器作用于电池上的压力为 300gf, 温度 25°C±1°C, 不包括电池引线。

4. Battery Cell Performance Criteria

电芯性能标准

4.1 Standard testing environment

标准测试环境

Unless specifically stated otherwise, tests must be done within one month of delivery and the number of charging-recharging cycles is fewer than 5. The following is test conditions:

Test conditions:

Ambient Temperature: 25°C ± 1°C

Ambient Humidity: 45~75%RH

除非另有说明, 测试应在电池出货的 1 个月内进行, 且充放电循环的次数少于 5 次。本产品规格书中的所有测试均在以下环境条件下进行:

温度: 25°C ± 1°C

湿度: 45~75%RH

4.2 The requirement of measure instrument

测量设备要求

- (1) The measurement instrument has been certified by a qualified source.
 - (2) The accuracy of the measuring instrument is less than 0.01mm.
 - (3) The accuracy of multimeter is at least 0.5%. While measuring the voltage, the internal resistance can not be less than 10KΩ.
 - (4) The principle internal resistance is 1KHz LCR; the accuracy is 0.2%.
 - (5) The internal resistance can vary based upon temperature and the charging mode. It is relevant to the PTC and the length and resistance of the wiring.
 - (6) The current accuracy of the battery test system is at least ±0.1%, isobarically accuracy is ±0.5%, and timer accuracy is not less than ±0.1%.
 - (7) The accuracy of the thermometer is at least ±0.5°C.
- (1) 测量设备、仪器需经检定机构检验合格。
 - (2) 测量尺寸的仪器精确度小于 0.01mm。
 - (3) 万用表测量电压及电流的准确度应不低于 0.5%, 测量电压时内阻应不小于 10KΩ。
 - (4) 内阻测试仪测量原理应为交流阻抗法 (1KHz LCR), 精确度为 0.2%。
 - (5) 内阻不是恒定值, 会随着温度和充电方式而变化。与装有 PTC 保护组件及引线长度、电阻有关。

Lithium Ion polymer battery

- (6) 电池测试系统的电流精度应在 $\pm 0.1\%$ 以上，恒压精度 $\pm 0.5\%$ ，计时精度不低于 $\pm 0.1\%$ 。
- (7) 测量温度的仪表准确度应不低于 $\pm 0.5^\circ\text{C}$ 。

4.3 Visual inspection

外观检查

There shall be no such defects defect as scratch ,flaw ,crack and leakage,which may adversely affect commercial value of the cell

不允许有任何影响电芯性能的外观缺陷，诸如裂纹、裂缝、泄露等。

4.4 Charge/Discharge Methods and Test Conditions 充放电方法和测试条件

No. 序号	Item 项目	Testing Conditions and Method 测试方法及条件
1	Standard Charging 标准充电	Constant Current Charging at 0.2C to 4.2V. Constant Voltage Charging at 4.2V to cut-off current $\leq 0.05\text{C}$ 先用 0.2C 恒流充电至 4.2V，再用 4.2V 恒压充电至截止电流 $\leq 0.05\text{C}$ 。
2	Quick Charging 快速充电	Constant Current Charging at 0.5C to 4.2V. Constant Voltage Charging at 4.2V to cut-off current $\leq 0.05\text{C}$ 先用 0.5C 恒流充电至 4.2V，再用 4.2V 恒压充电至截止电流 $\leq 0.05\text{C}$ 。
3	Standard Discharge 标准放电	Constant discharge at 0.2C to cut-off voltage of 2.8V. 用 0.2C 恒流放电至截止电压为 2.8V。
4	Charging Time 充电时间	Standard charging time : 8 hours(Ref) Quick charging time: 2.8 hours(Ref) 标准充电时间: 8 小时(参考值) 快速充电时间: 2.8 小时(参考值)

4.5 Mechanical Characteristics 机械特性

No. 序号	Item 项目	Testing Conditions and Method 测试方法及条件	Standard 标准
1	Vibration Test 振动测试	After standard charging, the cell is secured to a vibration table and subjected to vibration cycling in which the frequency is varied at the rate of 1Hz per minute between 10Hz and 55Hz; the excursion of the vibration is 0.38mm. The cell shall be vibrated for 30 minutes on each of X, Y, and Z axis. 将标准充电后的电芯固定在振动台上，并沿 X、Y、Z 三个方向各振动 30 分钟，振幅为 0.38mm，振动频率为 10Hz—55Hz，每分钟变化 1Hz。	No explosion, no fire 无爆炸、无起火

Lithium Ion polymer battery

2	Drop Test 跌落测试	A charged battery is dropped from a height of 1 meter two times onto a concrete surface. 标准充电后，将电芯 2 次从 1 米的高度跌落至混凝土地面。	No explosion, no fire 无爆炸、无起火
---	--------------------------	--	----------------------------------

4.6 Safety Test 安全测试

No. 序号	Item 项目	Testing Conditions and Method 测试方法及条件	Standard 标准
1	Over-charge 过充电	After standard charging, the cell is conducted for 8 hours while the constant voltage is held at 4.5V and standard charging current flows through it. 将标准充电后的电芯，用恒定电压 4.5V 和标准充电电流给电芯进行加压 8h。	No explosion, no fire 无爆炸、无起火
2	Short-circuit 短路	A charged battery is short-circuited for 1 hour at 0.04Ω. 将标准充电后的电芯，用 0.04 Ω 电阻器短接 1h。	No explosion, no fire 无爆炸、无起火
3	Heat shock 热冲击	The cell is placed in a thermal chamber. Temperature is raised to 120±2°C at the rate of (5±2°C)/min and held for 10 minutes, then cooled to room temperature at the rate of 5±2°C/min. 电池置于热箱中，温度以 (5±2°C) /min 的速率升至 120±2°C 并保温 10min，再以 5±2°C /min 的速度降至室温。	No explosion, no fire 无爆炸、无起火
4	Humidity and heat test 湿度和热度测试	A charged battery is placed in a box for 48 hours where the temperature is 40°C±2°C and the relative humidity is 90%~95% 将标准充电后的电芯放入温度为 40°C±2°C，相对湿度为 90%~95% 的箱子中，保持 48h。	No explosion, no fire 无爆炸、无起火

4.7 High and low temperature test 高低温性能测试

No. 序号	Item 项目	Testing Conditions and Method 测试方法及条件	Standard 标准
1	High Temperature 高温性能	A charged battery is placed in an oven for 2 hours at 55°C±2°C, then discharged at a 0.5C current to the termination voltage. 在 55°C±2°C 条件下，将标准充电后的电芯放入高温箱中 2h 后，再以 0.5C 电流放电至终止电压。	Discharge 90 percent of the original capacity. 可放出初始容量的 90%.

Lithium Ion polymer battery

2	Low Temperature 低温性能	<p>A charged battery is placed in a thermal chamber for 2 hours at $-10^{\circ}\text{C}\pm 2^{\circ}\text{C}$; then discharged at 0.1C to the termination voltage.</p> <p>在$-10^{\circ}\text{C}\pm 2^{\circ}\text{C}$条件下, 将标准充电后的电芯放入低温箱中 2h 后, 再以 0.1C 电流放电至终止电压。</p>	<p>Discharge more than 45 percent of the original capacity.</p> <p>可放出初始容量的 45% (-10°C) 以上。</p>
---	--------------------------------	--	--

4.8 Electricity maintenance 荷电保持能力

No. 序号	Item 项目	Testing Conditions and Method 测试方法及条件	Standard 标准
1	Electricity maintenance 荷电保持	<p>A charged battery sits for 28 days at ambient temperature of $25^{\circ}\text{C}\pm 1^{\circ}\text{C}$, then discharged at a 0.2C current to the termination voltage.</p> <p>在环境温度为 $25\pm 1^{\circ}\text{C}$ 的条件下, 将标准充电后的电芯搁置 28 天, 再以 0.2C 电流放电至终止电压。</p>	<p>Discharge more than 85 percent of the original capacity.</p> <p>可放出初始容量的 85% 以上。</p>

5. Storage and others

贮存及其它事项

5.1 Longterm Storage

长期贮存

If the cell is to be stored for 3 months or longer it should be held in a dry and cool environment. Voltage during storage needs to be maintained between 3.6V~3.85V and the storage conditions are the same as Item 4.1.

长期贮存的电池(超过 3 个月)须置于干燥凉爽处, 储存电压应保持在 3.6~3.85V, 且储存要求与 4.1 条相同。

5.2 Any issues not covered in this specification should be discussed between the customer and Guangzhou Jiezhentech Technology Co.,Ltd.

本说明书中未提及的任何事项, 须经双方协商确定。

6. Repair period

包修期限

The repair period is 6 months from the date that the batteries are shipped out from factory (the printing date on the cell).

产品包修期限为 6 个月, 自出厂日期 (喷码) 开始算起。

Lithium Ion polymer battery

7.Drawing

7.1 Assembly diagram (not to scale)

装配尺寸图(未按比例)

Model: 803565

Unit: mm

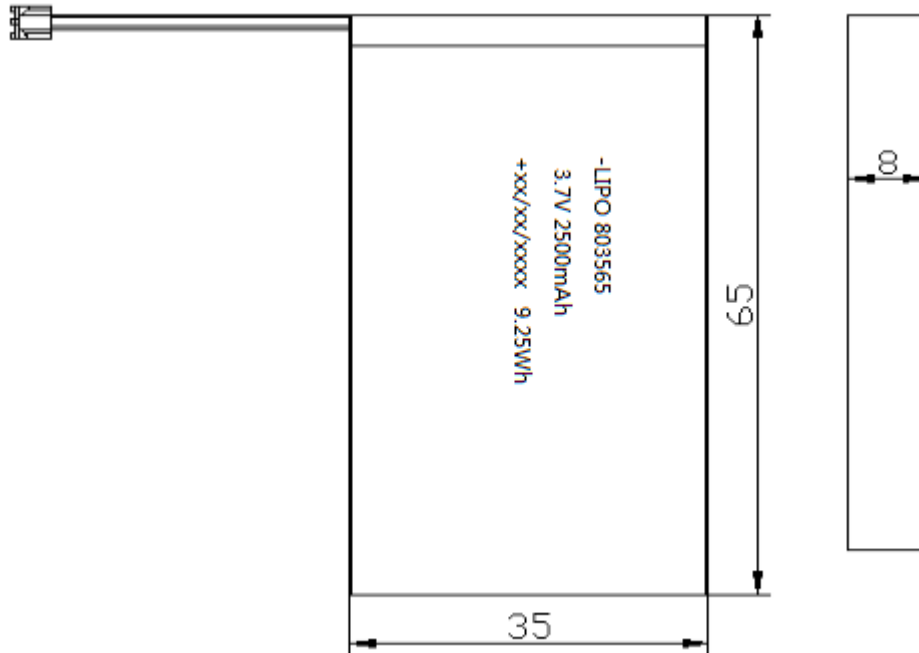

Unit 单位 (mm)					
T (厚度)Max	8.10mm	W (宽度) Max	35.00mm	H (高度) Max	65.00mm
L(引线外露长)	50mm ± 2.5mm	Con(插头)	PH-2P	WIRE (引线)	UL1007/24AWG

Handling Precaution and Guideline

For LIP (Lithium-Ion Polymer) Rechargeable batteries Preface

This document of 'Handling Precautions and Guidelines for LIPO Rechargeable Batteries' shall be applied to the battery cells manufactured by Guangzhou Jiezhen Technology Co., Ltd.

前言

本文件“聚合物锂离子充电电芯操作指示及注意事项”仅适用于广州捷臻科技有限公司生产的电芯。

Note (1): The customer is requested to contact Guangzhou Jiezhen Technology Co., Ltd in advance if and when the customer needs variations of the operating conditions described in this document. Additional experimentation may be required to verify performance and safety under such conditions.

注 (1):

客户若需要变动文件中规定的工作条件，应事先联系广州捷臻科技有限公司。需要额外进行试验以核实电芯在该使用条件下的性能及安全性。

Note (2): Guangzhou Jiezhen Technology Co., Ltd will take no responsibility for any accident when the cell is used under conditions outside of this specification.

注 (2):

对于在超出文件规定以外的条件下使用电芯而造成的任何意外事故，广州捷臻科技有限公司概不负责。

Note (3): Guangzhou Jiezhen Technology Co., Ltd will inform the customer in writing of improvement(s) regarding proper use and handling of the cell if it is deemed necessary.

Guangzhou Jiezhen Technology Co., Ltd Energy reserves the right to revise this specification before the customer signs the datasheet. If a revision is required, Guangzhou Jiezhen Technology Co., Ltd will notify the customer.

注 (3):

如有必要广州捷臻科技有限公司会以书面形式告知客户有关正确使用及操作电芯的改进措施。

在规格书未签确前，本公司有权对本产品规格书进行修订，如有必要修订后，广州捷臻科技有限公司将会通知客户。

1. Charging

充电

1.1 Charging Current:

充电电流

The charging current must be less than the maximum charge current specified in the Specification Approval Sheet.

充电电流不能超过本规格书中规定的最大充电电流。

1.2 Charging Voltage:

充电电压:

The charging voltage must be less than the maximum nominal voltage 4.2V.

充电电压不能超过本规格书中规定的最大标称电压 4.2V。

1.3 Charging Temperature:

充电温度:

Lithium Ion polymer battery

The cell must be charged within the range specified in this Specification Approval Sheet.
电芯必须在本规格书规定的环境温度范围内进行充电。

1.4 Notes:

Since charging is done with a constant current or a constant voltage, reverse charging is prohibited. If the cell is connected improperly it cannot be charged. Reverse charging can damage the cell and lead to degradation of cell performance, impair cell safety, and cause heat generation or leakage.

采用恒流恒压方式充电，禁止反向充电。若电池正、负极接反，将无法对电芯进行充电；同时，反向充电会降低电芯的充放电性能和安全性，并会导致发热和泄漏。

2. Discharging Current:

放电电流

The cell shall be discharged at less than the maximum discharge current specified in the Specification Approval Sheet. A high discharging current may reduce the discharge capacity significantly or cause overheating.

放电电流不得超过本规格书规定的最大放电电流，过大的放电电流会导致电芯容量剧减并导致电芯过热。

3. Discharging Temperature

放电温度

The Discharging Temperature must be within the range specified in this Specification Approval Sheet.
电芯放电温度必须在本规格书规定的环境温度范围内进行。

4. Over-Discharge

过放电

Over-discharging will cause cell degradation and functional losses. The cell can degrade into an over-discharge state through self discharging. In order to prevent over-discharging, the cell should be charged periodically to retain between 3.6V and 3.85V.

过放电会导致电芯性能及功能的丧失，要避免过放电。电芯长期未使用期间，它也可能因其自放电特性而处于某些过放电状态，为防止过放电的发生，电芯应定期充电，使其电压维持在 3.6V 到 3.85V 之间。

5. Protective Circuit Module

保护电路模块 (PCM)

5.1 The cell/battery pack shall contain a PCM that can protect the cell/ battery pack properly.

PCM shall have the following functions to ensure safety and prevent deterioration of cell performance:

- (1) overcharging prevention
- (2) over-discharging prevention
- (3) over current prevention.

电芯/电池外壳应装有 PCM 以正确保护电芯/外壳。

PCM 应具备以下功能以保证安全并防止电芯性能损坏:

- 1) 过充电保护; 2) 过放电保护; 3) 过流保护

5.2 Overcharging Protection

过充电保护

Overcharging prevention stops charging if any cell of the battery pack reaches 4.30V.

若电池中任一电芯的电压达 4.30V，过充电保护应立刻停止充电。

5.3 Over-discharging protection

过放电保护

Lithium Ion polymer battery

The Over-discharging protection monitors the voltage of every cell in the pack and works to avoid a drop in the cell voltage to 2.8V or less.

过放电保护监测每个电芯电压，并避免电压降至 2.8V 以下。

6. Storage

贮存

Cells should be stored at the proper temperature that is identified in the Specification Approval Sheet.

电芯应在产品规格书规定的温度范围内储存。

7. Notice

△注意事项

7.1 Handling of cells:

- ★ Don't charge the cells and keep them in a charged state for a long time.(Display units should dismantle the battery)
- ★ Avoid any short-circuit. It will cause the leads to get hot and lose electronic functions.
- ★ Soft package is easily damaged by sharp objects such as needles and knives. Avoid touching the cells with sharp objects when handling and storing.
- ★ Next to the leads is the sealed edge. Don't bend or fold the sealing edge as it is sensitive to movement.
- ★ Don't open the folded edge on the sides of the cell.
- ★ Don't bend the tabs as the tabs are sensitive.
- ★ Avoid mechanical shock to the cells.
- ★ Don't put the cells into an oven, washing machine or any high-voltage container.
- ★ Don't use a charger without a safety certification. Use only a recommended charger.
- ★ You should immediately stop charging if the cell overheats, emits an odor, changes color, changes shape, etc.
- ★ Adults should supervise the use of batteries by children.
- ★ Before using batteries, please carefully read and understand the handling guidelines.
- ★ Avoid electro-static discharge when using, charging, and storing cells.
- ★ Avoid putting the battery in contact with metal conductors such as neck chains, barrettes, or bolts, etc.
- ★ Don't use metal conductors to connect the positive and negative leads together.
- ★ Avoid errors during assembly by contacting the positive lead with the negative lead.
- ★ After full charge the battery,if the discharge time is less than 60% of normal discharge time , please immediately stop using and change it or contact with the customer service personnel to repair.

7.1 使用电芯时应注意

- ★ 电池不能长时间充电，不能长期处于充电状态。（如展示品需拆下电池）
- ★ 慎防短路，任何情况引起的短路可能会导致极耳金属发热，使电池功能失效。
- ★ 电芯属于软包装，包装材料易被尖锐物品刺伤，诸如尖针，刀片等，电芯在使用和存放时，应避免与尖锐物品碰撞。
- ★ 电芯极耳引出端为顶封边，顶封边为电芯密封敏感区，使用时，禁止弯折顶封边。
- ★ 禁止打开电芯两侧的折边。
- ★ 电芯极耳的机械强度并非异常坚固，禁止弯折极耳，特别是铝极耳。
- ★ 禁止机械撞击电芯、坠落、弯折电芯。
- ★ 不要把电池放在加热器皿、洗衣机或高压容器中。
- ★ 不要使用非指定的和没有安全认证的充电器给电池充电。
- ★ 在使用充电或储存期间如发现电池有变热、散发气味、变色、变形或其它反常之处应停止使用。
- ★ 把电池放到小孩够不到的地方以免吞服。

Lithium Ion polymer battery

- ★ 儿童使用电池时，监护人应详细解释操作方法。
- ★ 在使用电池之前，应仔细阅读操作指南并对使用中的注意事项有足够深刻的理解。
- ★ 电池应在远离静电的场所进行充电、使用和储存。
- ★ 不要在火源附近或温度超过 60°C 的轿车中使用或遗留电池，也不要这些环境中进行充放电。
- ★ 不要把电池同项链发夹硬币或螺钉等金属品一起放在手提包中，也不要将电池同上述物品一起储存。
- ★ 不要使用金属导体短路电池的正、负极。
- ★ 在使用时应注意电池的正、负极不要反装。
- ★ 不要使用带有严重变形的电池。
- ★ 若电池满充电后，放电使用时间低于正常使用的 60%，应立即停止使用并更换电池或联系客服人员维护。

7.2 Notice for Designing Battery Pack

电池外壳设计注意事项

7.2.1 Package Design

外壳设计

- ① The battery pack should have sufficient strength and the battery should be protected from mechanical shock.
- ② No sharp objects should be inside the pack containing the battery.
- ① 电池外壳应有足够的机械强度以确保其内部电芯免受机械伤害。
- ② 外壳内安装电芯的部位不应有锋利的边角。

7.2.2 PCM Design

保护电路模块设计

- ① The overcharge threshold voltage should be less than 4.30V (single pack).
- ② The over-discharge threshold voltage should not be lower than 2.8V (single pack).
- ③ The PCM should have short circuit protection.
- ① 过充的限制电压应小于 4.30V（单节电芯）。
- ② 过放的限制电压应大于 2.8V（单节电芯）。
- ③ 保护电路模块应具有短路保护功能。

7.3 Notice for Assembling Battery Pack

电池外壳组装注意事项

7.3.1 Tab connection

电芯的连接

- ① Ultrasonic welding or spot welding is recommended to connect the battery with the PCM or other parts.
- ② If the tab is to be soldered to the PCM, the instructions below are very important to ensure battery performance.
 - a) The solder iron should be temperature controlled and ESD safe.
 - b) Soldering temperature should not exceed $350 \pm 10^\circ\text{C}$.
 - c) Soldering time should not be longer than 3 seconds.
 - d) Soldering times should not be fewer than 5.
 - e) Let the battery tab cool down before soldering again.
 - f) Direct heat to the cell body is strictly prohibited. The battery will be damaged by heat above approx. 60°C .
- ① 建议使用超声波焊接或点焊技术来连接电芯与保护电路模块或其它部分。
- ② 如使用手工锡焊，须注意以下事项，以保证电芯的功能：
 - a) 烙铁的温度可控且防静电。

Lithium Ion polymer battery

- b) 烙铁的温度不能超过 $350 \pm 10^{\circ}\text{C}$ 。
- c) 锡焊时间不能超过 3 秒；
- d) 锡焊次数不能超过 5 次；
- e) 必须在极耳金属片冷却后再进行二次焊接；
- f) 禁止直接加热电芯，高于 60°C 会导致电芯损坏。

7.3.2 Cell fixing

电芯的安装

- ① The cell should be fixed to the battery pack by its large surface area.
 - ② There should be no sharp edges at the assembly contact area.
 - ③ Cells must be held firmly in the battery pack; movement is not allowed.
 - ④ The total thickness (the cell thickness plus the thickness of auxiliary materials, e.g. sponge pad, insulate pad, tape and so on) can't exceed the interior room of the plastic case, in order to prevent the cell from the damage and safe issue.
- ① 应将电芯的宽面安装在外壳内；
 - ② 装电芯的位置不能有毛刺和尖锐边角；
 - ③ 电芯不能在壳内活动。
 - ④ 电芯的厚度与辅助材料(如：海面垫、绝缘片、胶带等)的总厚度不能大于壳体内部空间尺寸，以免造成对电芯的损坏和安全隐患。

8. Others

其它注意事项

8.1 Disassembly may cause an internal short circuit to the cell, which may cause out-gassing, fire, or other problems.

在任何情况下不得拆卸或解剖电芯，拆卸和解剖可能会引致电芯内部短路，进而引起鼓气、冒烟、起火及其它安全问题。

8.2 LIP battery should not have liquid flowing, but in case the electrolyte come into contact with the skin, or eyes, physicians, we recommend as below:

电芯内容物理论上不存在流动的电解液，但万一电池密封不严或刺伤造成吸潮而泄漏接触到皮肤、眼睛、或身体其它部位，以下是建议预防措施：

- a. The electrolyte touch eyes: Flush the electrolyte immediately with fresh water for 15min. and medical advice is to be sought.
 - b. The electrolyte touch skin: Flush the electrolyte immediately with a great deal of fresh water.
 - c. Breath the released gas: Go outside to breath flash air.
 - d. Mis-eaten: Go to take some medical advice.
- a. 眼睛触到电芯内容物：立即用清水冲洗至少 15 分钟，如仍有不适，建议到相关医院就诊。
 - b. 皮肤接触：立即用大量的清水冲洗。
 - c. 吸入排放气体：换场所吸入新鲜空气。
 - d. 误食：需马上医疗就诊。

8.3 Prohibition of dumping of cells into fire

Never incinerate or dispose the cells in fire, for these may cause firing of the cells.

严禁将电芯投入火中

8.4 The cells should never be soaked with liquids such as water, drinks or oil.

严禁将电芯浸入液体中，如水，饮料，汽油等。

8.5 Prohibit using the cells mixed with different manufactories. Prohibit using new cells mixed with old ones.

禁止和不同厂家的电芯混用，禁止新旧电芯混用。

8.6 Prohibit using damaged cells.

禁止使用已损坏的电芯。

9. Recommended Notice:

推荐使用事项

9.1 Using cells on specified facilities only.

仅在指定的设备上使用电池。

9.2 Using cells in normal ambient temperature. Temperature: -10~35°C, Relative Humidity: 45~75%.

请在正常的室内环境中使用电池。温度-10~35°C，相对湿度：45~75%。

9.3 Using the cells, away from heat source. Don't let children play with cells. Don't drop cells. Charge cells with specified charger.

在使用过程中，应远离热源，避免儿童玩弄电池。切勿摔打电池。本电池只能使用配套标准充电器充电。

9.4 Avoid the positive pole shortcutting with the negative one. Avoid the cells affected with damp.

切勿将电池正、负极短路，切勿让电池受潮，以免发生危险。

9.5 Useless cells should be deal with in a safety way. Don't drop them into the water or fire.

废弃电池请安全妥当处理，不要投入火中或水中。

▲ Special Notice: If the cell isn't used for a long time, please keep the cells in a half-charged state neither fully charged and not completely discharged. Recharge the cells and use half of the power after 2-3 months. Store the cells in a cool and dry place. It will protect the cell from damage.

特别提醒：若电池长期不使用时，使其处于半充饱电状态（一半电量），即：不充满电，也不放完电。并在 2-3 个月之后重新充电，并使用一半电量，电池应在阴凉干燥处储存，这样可以使电池不受损坏。

附录

(JZ-ML76EH) 保护板规格书

1 Electrical characteristics 电气特性

T_{opt}=25°C

Item 项目	Symbol 符号	Content 详细内容	Criterion 标准
Over charge Protection 过充保护	V _{DET1}	Over charge detection voltage 过充电检测电压	4.28±0.025V
	t _{CU}	Over charge detection delay time 过充电检测延迟时间	0.1±0.05S
	V _{REL1}	Over charge release voltage 过充电解除电压	4.08±0.05V
Over discharge protection 过放保护	V_{DET2}	Over discharge detection voltage 过放电检测电压	3.0±0.05V
	t _{DL}	Over discharge detection delay time 过放电检测延迟时间	25±15mS
	V _{REL2}	Over discharge release voltage 过放解除电压	3.0±0.08V
Over current protection 过流保护	V _{DET3}	Over current detection voltage 过电流检测电压	0.10±0.04V
	IDP	Over current detection current 过电流保护电流	3.0-5.0A
	t _{IOV1}	Over current detection delay time 过电流检测延迟时间	10±5mS
		Release condition 保护解除条件	Cut load 断开负载
Short protection 短路保护		Detection condition 保护条件	Exterior short circuit 外部电路短路
		Release condition 保护解除条件	Cut short circuit 断开短路电路
	t _{IOV2}	Short circuit detection delay time 短路检测延迟时间	500~700 us
Interior resistance 内阻	RDS	Main loop electrify resistance 主回路通态电阻	VC=4.2V, RDS≤50mΩ
充电电流 Charge current		最大持续充电电流 Max continuous Charge current	1A
放电电流 Diccharge current		最大持续放电电流 Max continuous Diccharge current	2.5A

Lithium Ion polymer battery

2 Parts list 元件列表

NO	Location	Part name	Specification	Pack type	Q'ty
1	U1	Battery protection IC	HY2111-GB	SOT-23-6	1
2	U2	Silicon MOSFET	AO8820	TSSOP8	1
3	R2	Resistance	SMD $100\ \Omega \pm 5\%$	0402	1
4	R1	Resistance	SMD $2.0K\ \Omega \pm 5\%$	0402	1
5	C1	Capacitance	SMD $0.1\ \mu F / 16V$	0402	1
6	PCB	Print circuit board	GMB-ML76EH $18 \times 4.0 \times 0.6$		1

3 Application Circuit 主板电路原理图

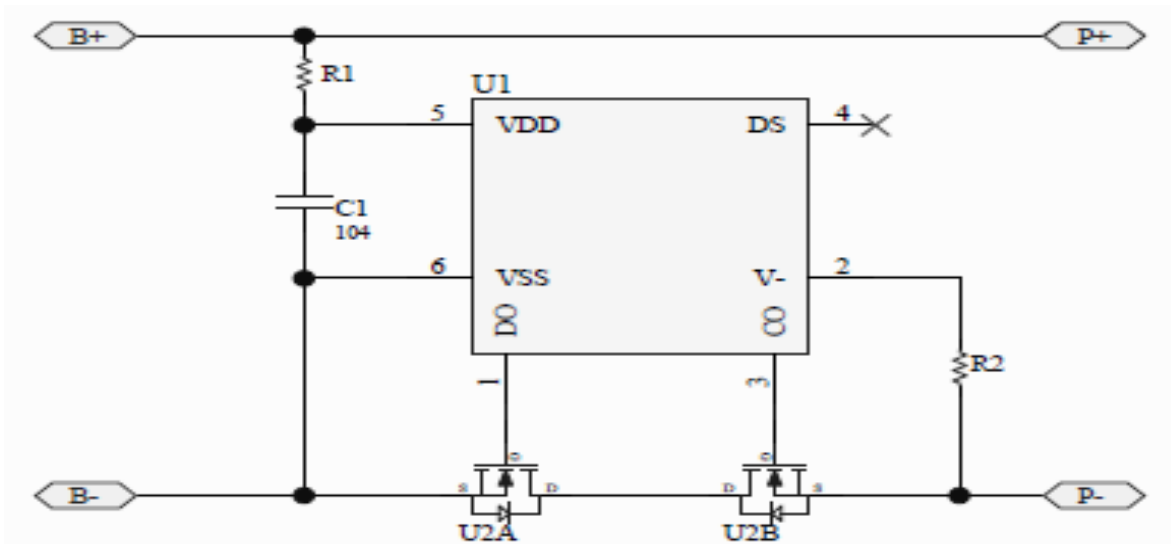

4 PCB layout

Top over view

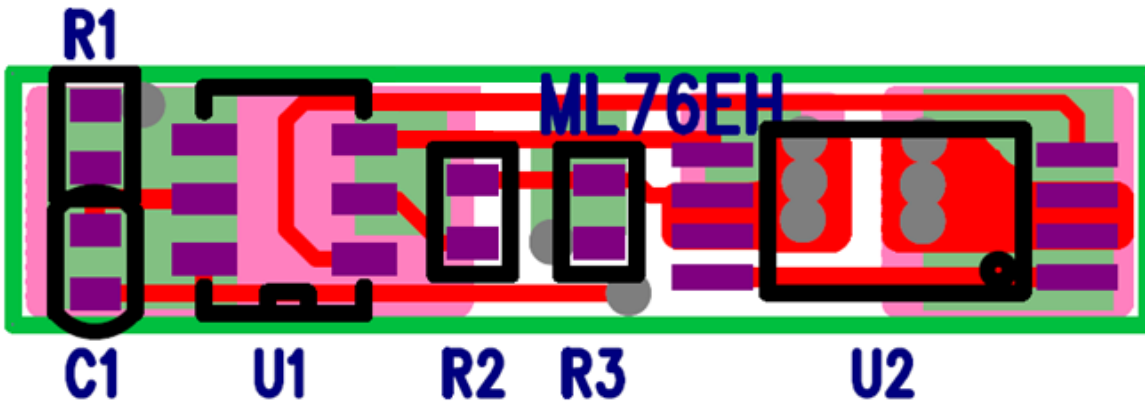

Lithium Ion polymer battery

top layer

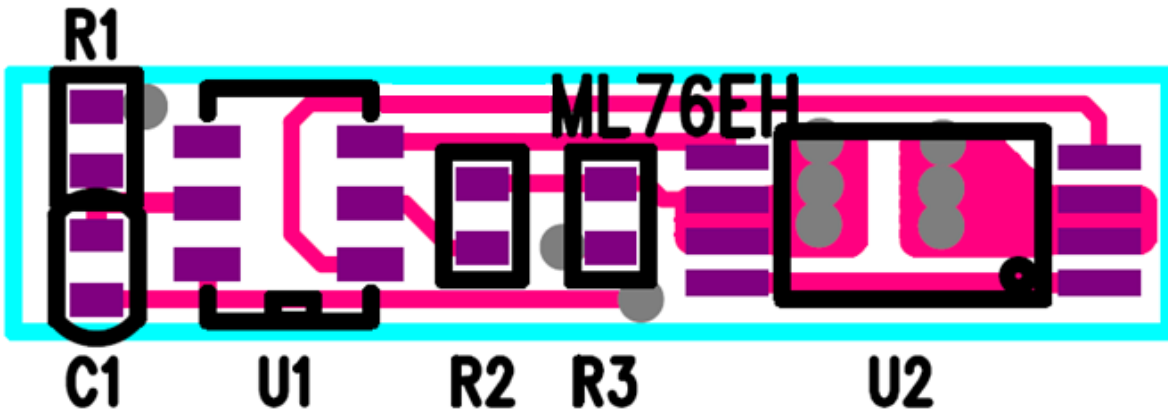

bottom layer

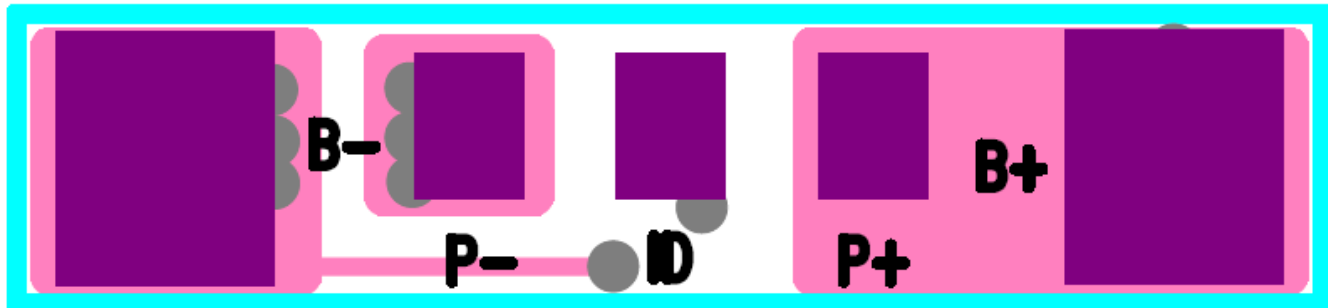

5 Terminal explanations

- B+: Connection cell +
- B-: Connection cell -
- P+: Connection output +
- P-: Connection output -

6 LEAD-FREE Product