



JZB-PL602540-M Battery Pack Spec

锂聚合物电池规格书

Model:
型号: JZB-PL602540-M

Customer:
客户代码: C23305

Customer P/N:
客户型号: _____

Nominal Voltage:
标称电压: 3.7V

Capacity:
容量: 600mAh

Draft 起草	Checking 审核	Approved 批准	Customer Confirmation 客户确认
Cathy	Jeff		



Revision History 版本记录

Revision 版本	Date 日期	Editor 编著	Contents 内容
A0	2020-05-07	Cathy	Draft
A1	2020-05-12	ZhanHuang	增加电池重量。



目录

1. Scope 适用范围.....	4
2. Product Specification 产品技术规格.....	4
3. Performance And Test Conditions 电池性能及测试条件.....	7
4. Mechanical characteristics and Safety Test for Cell 电芯安全测试及机械特性.....	8
5. Protection circuit 保护电路.....	10
6. Handling of Cells 电池操作注意事项.....	11
7. Storing the Batteries 电池的存放.....	11
8. Dimension 尺寸.....	12
9. Drawing Packing 包装图.....	12

1. Scope 适用范围

This specification is applied to the reference battery in this Specification and manufactured by Foshan Jiezen Technology Co.,ltd(JZB).

说明书适用于本书中所提及的科技佛山捷臻科技有限公司(JZB)制造的电池。

2. Product Specification 产品技术规格

Cell Battery 单电芯:

No. (序号)	Item (项目)	General Parameter (常规参数)		Remark (备注)
1	Rated Capacity (额定容量)	Typical (标称容量)	600mAh	Standard discharge (0.2C) after Standard charge (标准充电后 0.2C 标准放电)
		Minimum (最小容量)	588mAh	
2	Nominal Voltage (正常电压)	3.7V		Mean Operation Voltage (即工作电压)
3	Voltage at end of Discharge (放电终止电压)	2.75V		Discharge Cut-off Voltage (放电截止电压)
4	Charging Voltage (充电电压)	4.2±0.03V		
5	Internal Impedance (内阻)	≤100mΩ		Internal resistance measured at AC 1KHZ after 50% charge (半电态下用交流法测量内阻) The measure must uses the new batteries that within one week after shipment and cycles less than 5 times (使用出货后不到一个星期及循 环次数少于 5 次的新电池测量)
6	Weight 重量	About122g		
7	Standard charge (标准充电)	Constant Current 0.2C Constant Voltage 4.2V 0.01 C cut-off (持续电流: 0.2C 持续电压: 4.2V 截止电流: 0.01C)		
8	Standard discharge (标准放电)	Constant current 0.2C end voltage2.75V (持续电流: 0.2C 截止电压: 2.75V)		

Lithium Ion polymer battery

9	Fast charge (快速充电)	Constant Current 1.0C Constant Voltage 4.2V 0.01C cut-off (持续电流: 1.0C 持续电压: 4.2V 截止电流: 0.01C)	
10	Fast discharge (快速放电)	Constant current 1.0C end voltage 2.75V (持续电流: 1.0C 截止电压: 2.75V)	
11	Maximum Continuous Charge Current (最大充电持续电流)	600mA	
12	Maximum Continuous Discharge Current (最大放电持续电流)	600mA	
13	Operation Temperature Range (工作温度范围)	Charge (充电): 0~45°C	60±25%R.H. Bare Cell (单体电池储存湿度范围)
		Discharge (放电): -20~60°C	
14	Storage Temperature Range (储存温度范围)	Less than 1 year: -20~25°C (小于一年: -20~25°C)	60±25%R.H. at the shipment state (出货状态时的湿度范围)
		less than 3 months: -20~40°C (小于3个月: -20~40°C)	
15	Dimension Single cell (单电芯尺寸)	Length 长(L)	Initial Dimension (原始尺寸)
		Width 宽(W)	
		Height 高(H)	

Battery Pack 电池组:

No. (序号)	Item (项目)	General Parameter (常规参数)		Remark (备注)
1	Rated Capacity (额定容量)	Typical (标称容量)	600mAh	Standard discharge (0.2C) after Standard charge (标准充电后 0.2C 标准放电)
		Minimum (最小容量)	588mAh	
2	Nominal Voltage (正常电压)	3.7V		Mean Operation Voltage (即工作电压)
3	Voltage at end of Discharge (放电终止电压)	2.75V		Discharge Cut-off Voltage (放电截止电压)
4	Charging Voltage (充电电压)	4.2±0.03V		

Lithium Ion polymer battery

5	Internal Impedance (内阻)	$\leq 200\text{m}\Omega$	Internal resistance measured at AC 1KHZ after 50% charge (半电态下用交流法测量内阻) The measure must uses the new batteries that within one week after shipment and cycles less than 5 times (使用出货后不到一个星期及循环次数少于5次的新电池测量)
6	Weight 重量	About 125 g	
7	Standard charge (标准充电)	Constant Current 0.1C Constant Voltage 4.2V 0.01 C cut-off (持续电流: 0.1C 持续电压: 4.2V 截止电流: 0.01C)	
8	Fast discharge (快速放电)	Constant current 0.1C end voltage 2.75V (持续电流: 0.1C 截止电压: 2.75V)	
9	Maximum Continuous Charge Current (最大充电持续电流)	60mA	
10	Maximum Continuous Discharge Current (最大放电持续电流)	60mA	
11	Operation Temperature Range (工作温度范围)	Charge (充电): 0~45°C	60±25%R.H. Bare Cell (单体电池储存湿度范围)
		Discharge (放电): -20~60°C	
12	Storage Temperature Range (储存温度范围)	Less than 1 year: -20~25°C (小于一年: -20~25°C)	60±25%R.H. at the shipment state (出货状态时的湿度范围)
		less than 3 months: -20~40°C (小于3个月: -20~40°C)	
13	Battery Pack (电池组)	Length 长(L)	42.0±1mm
		Width 宽(W)	25.5±1mm
		Height 高(H)	6.2±0.5mm

3. Performance And Test Conditions 电池性能及测试条件

3.1 Standard Test Conditions 标准测试条件

Test should be conducted with new batteries within one week after shipment from our factory and the cells shall not be cycled more than five times before the test. Unless otherwise specified, test and measurement shall be done under temperature of $20 \pm 5^\circ\text{C}$ and relative humidity of 45~85%. If it is judged that the test results are not affected by such conditions, the tests may be conducted at temperature $15\sim 30^\circ\text{C}$ and humidity 25~85%RH.

测试必须使用出厂时间不超过一个星期的新电池，且未进行过五次以上的充放电循环。除非特别说明，否则测试会在温度 $20 \pm 5^\circ\text{C}$ ，相对湿度 45~85%的条件下进行。如果经鉴定测试结果不受上述条件影响，测试也可以在温度 $15\sim 30^\circ\text{C}$ ，相对湿度 25~85%RH 的条件下进行。

3.2 Measuring Instrument or Apparatus 测量器具及设备

3.2.1 Dimension Measuring Instrument 尺寸测量器具

The dimension measurement shall be implemented by instruments with equal or more precision scale of 0.01mm.

尺寸测量器具的精度等级应不小于 0.01 mm。

3.2.2 Voltmeter 伏特计

Standard class specified in the national standard or more sensitive class having inner impedance more than $10\text{k}\Omega/\text{V}$
按照国家标准指定规格等级或采用灵敏度更高的，测量电压时内阻不应小于 $10\text{k}\Omega/\text{V}$ 。

3.2.3 Ammeter 安培计

Standard class specified in the national standard or more sensitive class. Total external resistance including ammeter and wire is less than 0.01Ω .

按照国家标准指定规格等级或采用灵敏度更高的，包括电流表及电线在内的总外阻应小于 0.01Ω 。

3.2.4 Impedance Meter 电阻计

Impedance shall be measured by a sinusoidal alternating current method(1kHz LCR meter).

内阻测试仪测量原理应为交流阻抗法（1kHz LCR）。

3.3 Appearance 外观

There shall be no such defect as flaw, crack, rust, leakage, which may adversely affect commercial value of battery.

电池外观应没有划伤、破裂、污渍、生锈、漏液等影响市场价值的缺陷存在。

3.4 Temperature Dependence of discharge capacity 放电温度特性

Table 3 (表 3)

Discharge Temperature (放电温度)	-10°C	0°C	23°C	60°C
Discharge Capacity (0.2C) (放电容量/0.2C)	50%	80%	100%	95%

3.5 Cycle Life and Leakage-Proof 循环寿命及漏液试验

Table 4 (表 4)

Lithium Ion polymer battery

No. (序号)	Item (项目)	Criteria (标准)	Test Conditions (测试条件)
1	Cycle Life (循环寿命) (0.2C)	Higher than 70% of the Initial Capacities of the Cells (初始容量的 70%)	Carry out 500cycle Charging/Discharging in the below condition. ◆Charge: Standard Charge ◆Discharge:0.2C to 2.75 V ◆Rest Time between charge/discharge:30min. ◆Temperature:20±5°C 循环 500 次 充放电按以下条件: ◆充电: 标准充电 ◆放电:0.2C 放至 2.75V ◆搁置:30min. ◆温度:20±5°C
2	Leakage-Proof (漏液试验)	No leakage (visual inspection) (没有漏液/目测)	After full charge with standard charge, store at 55±3°C, 60±10%RH for 1 week. 标准充电条件下充满电后在温度 55±3°C, 湿度 60±10%RH 下储存一个星期

4. Mechanical characteristics and Safety Test for Cell 电芯安全测试及机械特性

Table 5 (表 5)

(Mechanical characteristics)

No. (序号)	Items (项目)	Test Method and Condition (测试方法及条件)	Criteria (标准)
1	Vibration Test 振动测试	After standard charging, fixed the cell to vibration table and subjected to vibration cycling that the frequency is to be varied at the rate of 1Hz per minute between 10Hz an 55Hz, the excursion of the vibration is 1.6mm. The cell shall be vibrated for 30 minutes per axis of XYZ axes. 将标准充电后的电芯固定在振动台上, 沿 X、Y、Z 三个方向各振动 30 分钟, 振幅 1.6mm, 振动频率为 10Hz~55Hz, 每分钟变化 1Hz。	No leakage 无泄漏 No fire 不起火
2	Drop Test 跌落测试	The cell is to be dropped from a height of 1 meter twice onto concrete ground. 将标准充电后的电芯从 1 米高度跌落至混凝土地面 2 次	No explosion, No fire, no leakage. 无爆炸、无起火、无泄漏

Table 6 (表 6)

(Safety Test)

Item (项目)	Battery Condition (电池要求)	Test Method (测试方法)	Requirements (要求)

Lithium Ion polymer battery

Crush (挤压试验)	Fresh, Fully charged (充满电的新电池)	Crush between two flat plates. Applied force is about 13kN(1.72Mpa) for 30min. (电池放置在两块平面金属板间, 施加 13KN (1.72Mpa) 的作用力, 且持续保持 30 分钟)	No explosion, No fire (无起火无爆炸)
Short Circuit (短路试验 20℃)	Fresh, Fully charged (充满电的新电池)	Each test sample battery, in turn, is to be short-circuited by connecting the (+) and (-) terminals of the battery with a Cu wire having a maximum resistance load of 0.1 Ω .Tests are to be conducted at room temperature(20±2℃). (在常温下约 20±2℃ 依次把每个样品电池的正负极用铜线连接起来使电池外部短路--线路总电阻不超过 0.1 Ω)	No explosion, No fire The Temperature of the surface of the Cells are lower than 150℃ (无起火无爆炸 电池表面温度应低于 150℃)
Short Circuit (短路试验 60℃)	Fresh, Fully charged (充满电的新电池)	Each test sample battery, in turn, is to be short-circuited by connecting the (+) and (-) terminals of the battery with a Cu wire having a maximum resistance load of 0.1 Ω .Tests are to be conducted at temperature(60±2℃). (在常温下约 60±2℃ 依次把每个样品电池的正负极用铜线连接起来使电池外部短路--线路总电阻不超过 0.1 Ω)	No explosion, No fire The Temperature of the surface of the Cells are lower than 150℃ (无起火无爆炸 电池表面温度应低于 150℃)
Impact (冲击试验)	Fresh, Fully charged (充满电的新电池)	A 56mm diameter bar is inlaid into the bottom of a 10kg weight. And the weight is to be dropped from a height of 1m onto a sample battery and then the bar will be across the center of the sample. (用一条直径为 56mm 的圆棒放置在电池中央, 将一 10Kg 的重锤从 1m 的高度垂直落下在电池的中心位置)	No explosion, No fire (无起火无爆炸)
Forced Discharge (过放试验)	Fresh, Fully charged (充满电的新电池)	Discharge at a current of 1.0C for 2.5h. (以 1.0C 的电流放电 2.5 小时)	No explosion, No fire (无起火无爆炸)
Nail Pricking (针刺试验 (3mm))	Fresh, Fully charged (充满电的新电池)	Prick through the sample battery with a nail having a diameter of 3mm and remain 2h. (用直径为 3mm 的钉子刺穿电池并保持 2 个小时)	No explosion, No fire (无起火无爆炸)

5. Protection circuit 保护电路

(Battery Pack PCM Standard 保护板标准)

Item (项目)	Symbol (符号)	Content (详细内容)	Criterion (标准)
Current (电流)	IDP	Max. Charging Current (最大持续充电电流)	1.5A
		Max. Discharging Current (最大持续放电电流)	1.5A
Over charge Protection (过充保护)	V _{DET1}	Over charge detection voltage (过充电检测电压)	4.28±0.05V
	tV _{DET1}	Over charge detection delay time (过充电检测延迟时间)	50—270ms
	V _{REL1}	Over charge release voltage (过充电解除电压)	4.15±0.05V
Over discharge protection (过放保护)	V _{DET1}	Over discharge detection voltage (过放电检测电压)	3.0±0.1V
	tV _{DET1}	Over discharge detection delay time (过放电检测延迟时间)	5-25ms
	V _{REL1}	Over discharge release voltage (过放解除电压)	3.10±0.1V
Over current protection (过流保护)	V _{DET3}	Over current detection voltage (过电流检测电压)	150±30mV
	IDP	Over current detection current (过电流保护电流)	2~5A
	tV _{DET3}	Detection delay time (检测延迟时间)	5-26ms
		Release condition (保护解除条件)	Cut load (断开负载)
Short protection (短路保护)		Detection condition (保护条件)	Exterior short circuit (外部电路短路)
	T _{SHOR} T	Detection delay time (检测延迟时间)	5-50ms
		Release condition (保护解除条件)	Cut short circuit (断开短路电路)
Interior resistance (内阻)	R _{D5}	Main loop electrify resistance (主回路通态电阻)	VC=4.2V,RDS≤70mΩ
Current consumption (消耗电流)	IDD	Current consume in normal operation (工作时电路内部消耗)	3.0 μ A Type 6.0 μ A Max

6. Handling of Cells 电池操作注意事项

5.1 Consideration of strength of film package 包装薄膜注意事项

1) Soft Aluminium foil 铝箔软包装

Easily damaged by sharp edge parts such as pins and needles, Ni-tabs, comparing with metal-can-cased LIB.

相对于金属壳的方形电池，铝箔软包装比较容易被锐利部件刺损，如针尖、镍带。

2). Sealed edge may be damaged by heat above 100°C, bend or fold sealed edge.

封边被加热到 100°C 以上以及弯折封边都容易使封边受损。

5.2 Prohibition short circuit 禁止电池短路

Never make short circuit cell. It generates very high current which causes heating of the cells and may cause electrolyte leakage, gassing or explosion that are very dangerous.

The tabs may be easily short-circuited by putting them on conductive surface.

Such outer short circuit may lead to heat generation and damage of the cell.

An appropriate circuitry with PCM shall be employed to protect accidental short circuit of the battery pack.

避免电池短路。短路会产生很高的电流而使电池发热以及电解液泄漏，产生有毒气体或爆炸是非常危险的。极片连接在导电物体表面很容易短路，外部短路会导致发热及损害电池。选用一个适当的保护电路可以在意外短路时保护电池。

5.3. Mechanical shock 机械撞击

JZB cells have less mechanical endurance than metal-can-cased LIB.

Falling, hitting, bending, etc. may cause degradation of JZB characteristics.

聚合物电池比金属壳方形电池的机械耐久性更小。

跌落、碰撞、弯曲等等都可能会降低聚合物电池的性能。

5.4 Handling of tabs 极片操作注意事项

The battery tabs are not so stubborn especially for aluminum tab.

Don't bend tab.

Do not bend tabs unnecessarily.

极片的机械强度并非异常坚固，特别是铝片。没有必要时禁止弯折极片。

7. Storing the Batteries 电池的存放

The batteries should be stored at room temperature, charged to about 30% to 50% of capacity.

We recommend that batteries be charged about once per half a year to prevent over discharge.

电池应当在室温下存放，应充到 30%至 50%的电量。如长时间储存，建议每半年充一次电以防止电池过放电。

8. Dimension 尺寸

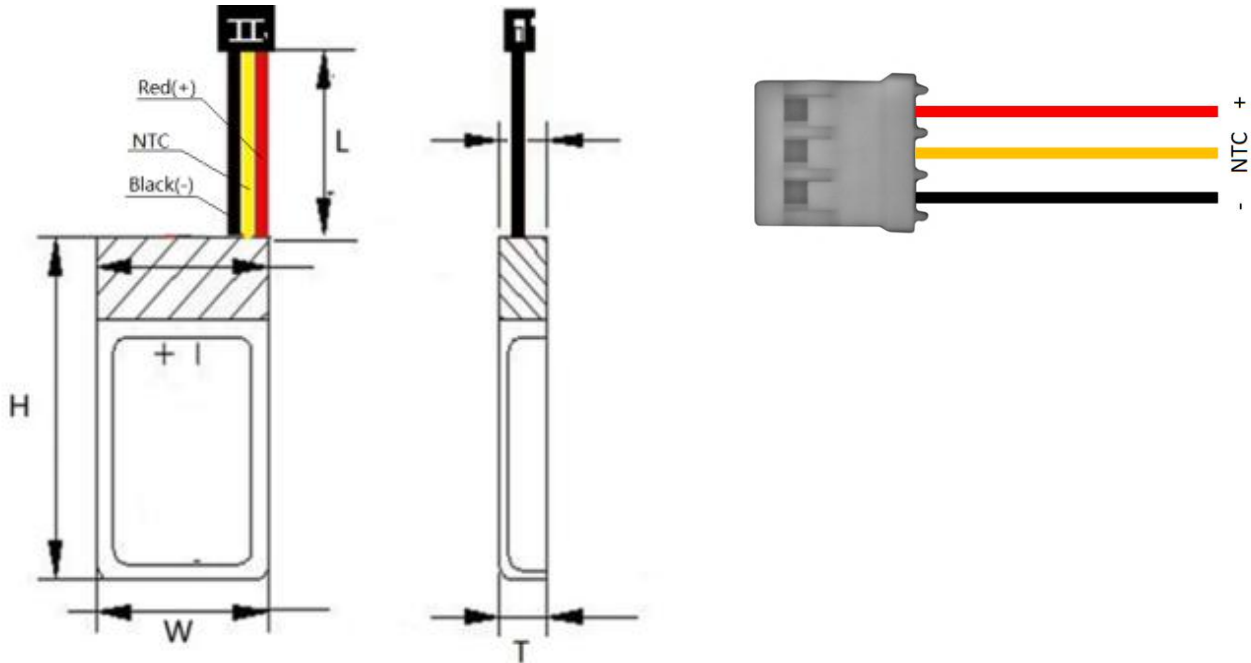

Dimensions 尺寸 (Units 单位: mm)	PCM	精工保护板 Normal PCM (1.5A) +10Kntc
	Length Cable 线长 (L)	80±5mm (注: 不含插头)
	Length 长(L)	42.0±1mm
	Width 宽(W)	25.5±1mm
	Height 高(H)	6.2±0.5mm
	Cable 线号	UL1571#26AWG
	Plug 插头	Molex 874390 300 反向 (仿)
Label 喷码印字:		
<div style="border: 1px solid black; padding: 5px;"> <p>JZ BATTERY PL602540 3.7V 600mAh DD/MM/YYYY 2.22WH</p> </div>		注: 印字日期随出货时间更改, DD 为日, MM 为月, YYY 为年, 如 07/05/2020 (2020年05月07日)

9. Drawing Packing 包装图

整齐入托盘; 再装箱, 每箱不超 10KG; 中性纸箱。